

# mitsubishi

---

# MELSECNET/H

# Network Module

---

User's Manual  
(Hardware)

**QJ71LP21GE**  
**QJ72LP25GE**

Thank you for purchasing the Mitsubishi programmable controller  
MELSEC-Q Series.

Prior to use, please read both this manual and detailed manual  
thoroughly and familiarize yourself with the product.

**MELSEC-Q**  
Mitsubishi  
Programmable Controller

MODEL	Q-LPGE-U-HW-E
MODEL CODE	13JR34
IB(NA)-0800183-E(0703)MEE	

## ● SAFETY PRECAUTIONS ●

(Always read these instructions before using this equipment.)

Before using this product, please read this manual and the relevant manuals introduced in this manual carefully and pay full attention to safety to handle the product correctly.

Precautionary notes in this manual cover only the installation of this product. For precautions on designing and discarding this product, refer to "Safety Precautions" in the MELSECNET/H Reference Manual.

For safety precautions on the programmable controller system, refer to the CPU User's Manual.

In this manual, the safety instructions are ranked as "DANGER" and "CAUTION".



Indicates that incorrect handling may cause hazardous conditions, resulting in death or severe injury.



Indicates that incorrect handling may cause hazardous conditions, resulting in medium or slight personal injury or physical damage.

Note that the  **CAUTION** level may lead to a serious consequence according to the circumstances.

Always follow the instructions of both levels because they are important to personal safety.

Please store this manual in a safe place and make it accessible when required. Always forward it to the end user.

## [INSTALLATION PRECAUTIONS]

### CAUTION

- Use the programmable controller in the operating environment that meets the general specifications given in the user's manual of the CPU module. Using the programmable controller in any other operating environment may cause an electric shock, fire or malfunction, or may damage or degrade the product.
- While holding the module mounting lever at the bottom of module, insert the module fixing tab into the fixing hole in the base unit. Then secure the module using the module fixing hole as a support point.  
Incorrect mounting may cause malfunctions, a failure or a drop of the module. In an environment of frequent vibrations, secure the module with the screw. Tighten the screw within the specified torque range.  
If the screw is too loose, it may cause a drop of the module, a short circuit or malfunctions.  
If too tight, it may damage the screw and/or the module, resulting in a drop of the module, a short circuit or malfunctions.
- Completely turn off the externally supplied power used in the system before mounting or removing the module. Failure to do so may damage the product.
- Modules of function version D or later can be replaced online on the remote I/O station. Nevertheless, there are some restrictions on the online-replaceable modules and replacement procedures are predetermined for each module. For details, refer to the Q Corresponding MELSECNET/H Network System Reference Manual (Remote I/O network).
- Do not directly touch the conducting parts and electronic parts of the module. This may cause the module to malfunction or fail.
- Before handling the module, touch a grounded metal object to discharge the static electricity from the human body. Failure to do so may cause malfunction or failure of the module.

## [WIRING PRECAUTIONS]

### **DANGER**

- Completely turn off the externally supplied power used in the system when installing or placing wiring.  
Failure to do so may cause electric shocks or damage the product.

### **CAUTION**

- Be careful not to let foreign objects such as dust and wire chips get inside the module. They may cause a fire, mechanical breakdown or malfunction.
- The top surface of the module is covered with a protective film to prevent foreign objects such as wire chips from entering the module during wiring work. Do not remove this film until all the wiring work is complete. Before operating the system, be sure to remove the film to release the heat.
- Make sure to place the communication and power cables into a duct or fasten them using a clamp. Failure to do so may damage the module or cables by pulling a dangling cable inadvertently or cause the module to malfunction due to bad connection.
- When disconnecting a communication cable, do not pull it by holding the cable part. To disconnect the cable, hold its connector that is plugged into the module. Pulling the cable part with the cable still connected to the module may damage the module and/or cable, or cause malfunctions due to poor cable contact.
- Install our programmable controller in a control panel for use.  
Wire the main power supply to the power supply module installed in a control panel through a distribution terminal block.  
Furthermore, the wiring and replacement of a power supply module have to be performed by a maintenance worker who acquainted with shock protection.  
For the wiring methods, refer to QCPU User's Manual (Hardware Design, Maintenance and Inspection).

## About the Manuals

The following manuals are also related to this product.  
In necessary, order them by quoting the details in the tables below.

### Related Manuals

Manual name	Manual No. (Model code)
Q corresponding MELSECNET/H Network System Reference Manual (PLC to PLC network)	SH-080049 (13JF92)
Q corresponding MELSECNET/H Network System Reference Manual (Remote I/O network)	SH-080124 (13JF96)
For QnA/Q4AR corresponding MELSECNET/10 Network System Reference Manual	IB-66690 (13JF78)

### Compliance with the EMC Directive and the Low Voltage Directive

When incorporating the Mitsubishi programmable controller into other industrial machinery or equipment and keeping compliance with the EMC and low voltage directives, refer to Chapter 3 "EMC Directive and Low Voltage Instruction" of the User's Manual (Hardware) for the CPU module used or the programmable controller CPU supplied with the base unit.

The CE logo is printed on the rating plate of the programmable controller, indicating compliance with the EMC and low voltage directives.

For making this product compliant with the EMC and low voltage directives, please refer to Section 3.1.3 "Cable" in Chapter 3 of the above-mentioned user's manual.

# 1. Overview

This manual explains how to handle the MELSECNET/H network module, model numbers QJ71LP21GE and QJ72LP25GE (hereinafter referred to as the network module).

After unpacking the network module, confirm that any of the following products is enclosed.

Model number	Description	Quantity
QJ71LP21GE	Model QJ71LP21GE MELSECNET/H network module (optical loop type)	1
QJ72LP25GE	Model QJ72LP25GE MELSECNET/H network module (optical loop type)	1

## 2. Performance Specifications

### 2.1 Performance specifications for the network module.

#### (1) QJ71LP21GE

Item		Specifications		
Maximum number of link points per network		(1) PLC to PLC network		
		MELSECNET/H mode, MELSECNET/H Extended mode *1	MELSECNET/10 mode *1	
		LX/LY	8192 points	8192 points
		LB	16384 points	8192 points
		LW	16384 points	8192 points
		(2) Remote I/O network		
LX/LY	8192 points			
LB	16384 points (Remote master station to Remote submaster station, Remote I/O station: 8192 points), (Remote submaster station, Remote I/O station to Remote master station: 8192 points)			
LW	16384 points (Remote master station to Remote submaster station, Remote I/O station: 8192 points), (Remote submaster station, Remote I/O station to Remote master station: 8192 points)			
Maximum number of link points per station	PLC to PLC network	<ul style="list-style-type: none"> <li>MELSECNET/H mode, MELSECNET/10 mode <math>\{(LY + LB) / 8 + (LW \times 2)\} \leq 2000</math> bytes *2</li> <li>MELSECNET/H Extended mode <math>\{(LY + LB) / 8 + (LW \times 2)\} \leq 35840</math> bytes *2</li> </ul>		
	Remote I/O network	<ul style="list-style-type: none"> <li>Remote master station → Remote I/O station *3 <math>\{(LY + LB) / 8 + (LW \times 2)\} \leq 1600</math> bytes</li> <li>Remote I/O station → Remote master station *3 <math>\{(LX + LB) / 8 + (LW \times 2)\} \leq 1600</math> bytes</li> <li>Multiplexed remote master station ↔ Multiplexed remote sub-master station <math>\{(LY + LB) / 8 + (LW \times 2)\} \leq 2000</math> bytes</li> </ul>		
Communication speed		10Mbps		
Communication method		Token ring		
Synchronous method		Frame synchronous method		
Transmission path format		Duplex loop		
Maximum number of networks		239		
Maximum number of groups		32 (9 in MELSECNET/10 mode in PLC to PLC network)		
Number of stations per network	PLC to PLC network	64 stations (control station: 1, normal station: 63)		
	Remote I/O network	65 stations (Remote master station: 1, Remote I/O station: 64) *4		
Overall distance		30 km (98430 ft.)		
Distance between stations		GI-62.5/125 optical cable: 2km (6562 ft.)		
Connection cable		Optical fiber cable (Arranged by user *5)		
Applicable connector		2-core optical connector plug (Arranged by user *5)		
Number of I/O occupied points		32 points (I/O assignment: intelligent 32 points)		
5 VDC current consumption		0.55 A		
External dimensions		98 (3.86 in.) (H) × 27.4 (1.08 in.) (W) × 90 (3.54 in.) (D)[mm]		
Weight		0.11 kg		

- \*1: Mode selection is performed using network parameters.
- \*2: The number of LY points of the stations set in the I/O master station is the sum total of the LY points for output to all stations within the block.
- \*3: The remote master station includes the multiplexed remote master station and multiplexed remote sub-master station.
- \*4: On a multiplexed remote I/O network, one of 64 remote I/O stations works as a multiplexed remote sub-master station.
- \*5: Specialized skill and specific tools are required to connect the connector to the optical fiber cable; the connector itself is a custom product. Please contact your nearest Mitsubishi Electric Europe GmbH when purchasing these items.

## (2) QJ72LP25GE

Item	Specifications	
Maximum number of link points per network	LX/LY	8192 points
	LB	16384 points (Remote master station to Remote submaster station, Remote I/O station: 8192 points), (Remote submaster station, Remote I/O station to Remote master station: 8192 points)
	LW	16384 points (Remote master station to Remote submaster station, Remote I/O station: 8192 points), (Remote submaster station, Remote I/O station to Remote master station: 8192 points)
Maximum number of link points per station	<ul style="list-style-type: none"> <li>• Remote master station → Remote I/O station *1  <math>\{(LY + LB) / 8 + (LW \times 2)\} \leq 1600</math> bytes</li> <li>• Remote I/O station → Remote master station *1  <math>\{(LX + LB) / 8 + (LW \times 2)\} \leq 1600</math> bytes</li> <li>• Multiplexed remote master station  ↔ Multiplexed remote sub-master station  <math>\{(LY + LB) / 8 + (LW \times 2)\} \leq 2000</math> bytes</li> </ul>	
Maximum number of I/O points per remote I/O station	$X + Y \leq 4096$ points When X/Y number overlaps, either of them becomes effective.	
Communication speed	10Mbps	
Communication method	Token ring	
Synchronous method	Frame synchronous method	
Transmission path format	Duplex loop	
Maximum number of networks	239	
Maximum number of groups	32	
Number of stations per network	65 stations (Remote master station: 1, Remote I/O station: 64) *2	
Overall distance	30 km (98430 ft.)	
Distance between stations	GI-62.5/125 optical cable: 2km (6562 ft.)	
Connection cable	Optical fiber cable (Arranged by user *3)	
Applicable connector	2-core optical connector plug (Arranged by user *3)	
Base unit installation position	CPU slot	
5 VDC current consumption	0.89 A	
External dimensions	98 (3.86 in.) (H) × 27.4 (1.08 in.) (W) × 90 (3.54 in.) (D) [mm]	
Weight	0.15 kg	

- \*1: The remote master station includes the multiplexed remote master station and multiplexed remote sub-master station.
- \*2: On a multiplexed remote I/O network, one of 64 remote I/O stations works as a multiplexed remote sub-master station.
- \*3: Specialized skill and specific tools are required to connect the connector to the optical fiber cable; the connector itself is a custom product. Please contact your nearest Mitsubishi Electric Europe GmbH when purchasing these items.

For general specifications of the network module, refer to the user's manual for the CPU that is to be used.



## 2.2 GI-62.5/125 optical fiber cable specifications

### (1) Applicable cable specifications

- The specifications for the GI-62.5/125 cable are given below.
- If you prepare a GI-62.5/125 cable yourself, it must comply with the specifications indicated below.

Item	Specification
Fiber type	GI (graded index) type multimode quartz glass
Core diameter	62.5 $\mu$ m
Clad diameter	125 $\mu$ m
Transmission loss	3dB/km or less
Wave length	0.85 $\mu$ m
Transmission band	300 MHz km or more

### (2) Cable loss

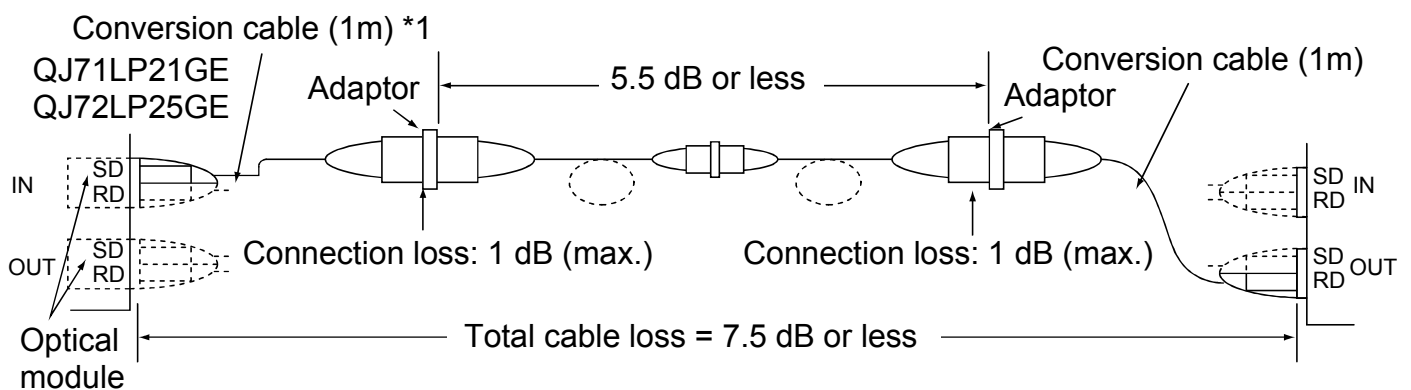

\*1: Conversion cable

Conversion Type	Cable
CA type ↔ FC type	AGE-1P-CA/FC1.5M-A
CA type ↔ ST type	AGE-1P-CA/ST1.5M-A
CA type ↔ SMA type	AGE-1P-CA/SMA1.5M-A

Purchased from: Mitsubishi Electric Europe GmbH

## 3. Handling

### CAUTION

- Use the programmable controller in the operating environment that meets the general specifications given in the user's manual of the CPU module. Using the programmable controller in any other operating environment may cause an electric shock, fire or malfunction, or may damage or degrade the product.
- While holding the module mounting lever at the bottom of module, insert the module fixing tab into the fixing hole in the base unit. Then secure the module using the module fixing hole as a support point. Incorrect mounting may cause malfunctions, a failure or a drop of the module. In an environment of frequent vibrations, secure the module with the screw. Tighten the screw within the specified torque range. If the screw is too loose, it may cause a drop of the module, a short circuit or malfunctions. If too tight, it may damage the screw and/or the module, resulting in a drop of the module, a short circuit or malfunctions.
- Completely turn off the externally supplied power used in the system before mounting or removing the module. Failure to do so may damage the product.
- Modules of function version D or later can be replaced online on the remote I/O station. Nevertheless, there are some restrictions on the online-replaceable modules and replacement procedures are predetermined for each module. For details, refer to the Q Corresponding MELSECNET/H Network System Reference Manual (Remote I/O network).
- Do not directly touch the conducting parts and electronic parts of the module. This may cause the module to malfunction or fail.
- Before handling the module, touch a grounded metal object to discharge the static electricity from the human body. Failure to do so may cause malfunction or failure of the module.

### 3.1 Handling Precautions

- (1) Since the module case is made of resin, do not drop it or subject it to strong impact.
- (2) The module can easily be secured to the base unit using the hooks located at the top of the module. In places where there are frequent vibrations, however, it is recommended to fix the module with the module fixing screws. In this case, tighten the module fixing screws within the following clamping torque range.  
Module fixing screws (M3): Tightening torque range is 0.36 to 0.48 N·m.

## 4. Part Identification Names

QJ71LP21GE

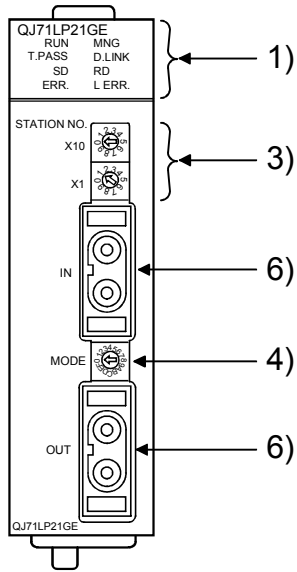

QJ72LP25GE

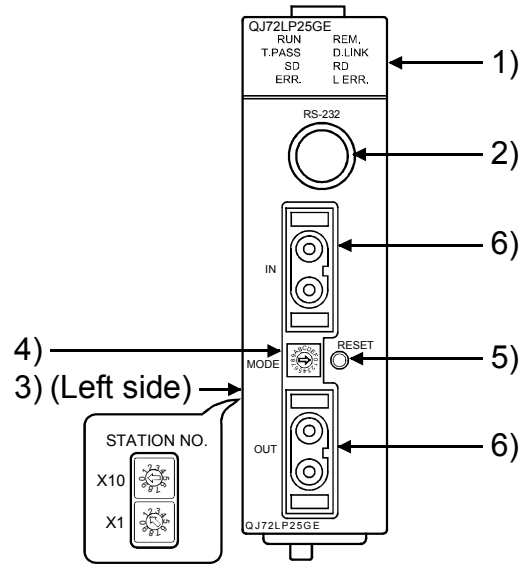

Number	Name	Reference Section
1)	Display LED	(1) in this chapter
2)	RS-232 connector	-
3)	Station number setting switches	(2) (a) in this chapter

Number	Name	Reference Section
4)	Mode setting switch	(2) (b) in this chapter
5)	RESET switch *1	-
6)	Connector	(3) in this chapter

\*1: To reset the module, press the RESET switch for 1 second or more. Pressing it less than 1 second may result in improper resetting. In such a case, reset it again.

## (1) Display contents for LEDs

QJ71LP21GE  
 RUN □ □MNG  
 T.PASS □ □D.LINK  
 SD □ □RD  
 ERR. □ □L ERR.

QJ72LP25GE  
 RUN □ □REM.  
 T.PASS □ □D.LINK  
 SD □ □RD  
 ERR. □ □L ERR.

LED name	Display contents
RUN	On: Operating normally Off: Watchdog timer error occurred (hardware fault)
T. PASS	On: Executing baton pass Flicker: Executing test Off: Baton pass not yet executed (host is disconnecting)
SD	On: Data being transmitted Off: Data not yet transmitting
ERR.*1	On: Setting error occurred Flicker: <ul style="list-style-type: none"> <li>• Error detected by a test</li> <li>• The mode setting switch or the station number setting switch was changed during operation</li> </ul> Off: No setting error
MNG	On: Operating as a control station, sub-control station, remote master station or remote sub-master station Off: Operating as a normal station
REM.*1	On: Operating normally Flicker: Flash ROM is being written or the device of the parameter is being tested Off: In remote initialization, watchdog timer error, blown fuse error, input/output verification error
D. LINK	On: Data link being executed Off: Data link not yet executed
RD	On: Data being received Off: Data not yet received
L ERR.	On: Communication error occurred Off: No communication error

\*1: When the remote I/O module is used in the redundant power supply system, the REM. and ERR. LEDs indicate the failure cause of the power supply module(s) as follows.

Power supply module	Failure cause	REM. LED	ERR. LED
Only one module failed	Input power supply OFF, fuse blown	Off	On
	Internal fault	Off On	On Off
Both of two failed	Input power supply OFF, fuse blown	Off	Off
	Internal fault	Off	Off
		On	On Off

When a remote I/O module of function version C or earlier has been used, the ERR. LED remains OFF even if one or two power supply modules went down. For failure of a power supply module, check the LED on the power supply module. If it is mounted on the extension base unit, the status can be also checked by the power supply module's ERR contact. (Refer to the QCPU User's Manual (Hardware Design, Maintenance and Inspection) for the LED specifications of the power supply module.)

(2) Setting contents for each switch

(a) Station number setting switches

1) QJ71LP21GE

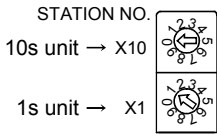

Switch name	Setting content	Type	Setting range	Setting at time of shipment
Station number setting switches	Sets the station number	PLC to PLC network	1 to 64 Setting error for other than the above	1
		Remote I/O network	0: Remote master station Setting error for other than the above	

2) QJ72LP25GE

Switch name	Setting content	Setting range	Setting at time of shipment
Station number setting switches	Sets the station number	1 to 64: Remote I/O station Setting error for other than the above	1

(b) Mode setting switch



Switch name	Setting content	Type	Setting range	Setting at time of shipment
Mode setting switch *1	Sets the operating mode	PLC to PLC network • Remote I/O network	0: On-line 1: Self-loopback test 2: Internal self-loopback test 3: Hardware test 4 to F: Use prohibited	0

\*1: Control station, normal station of PLC to PLC network or remote I/O network when making to online with Mode setting switch remote master station and remote I/O station is made the switch the same set.

(3) Connector

(a) IN/OUT connector

Connected with an optical fiber connector.

1) QJ71LP21GE

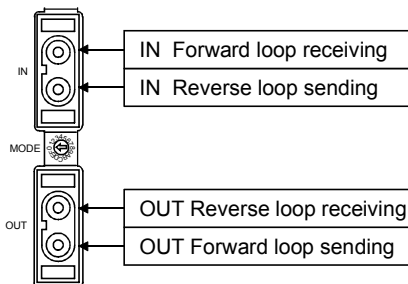

2) QJ72LP25GE

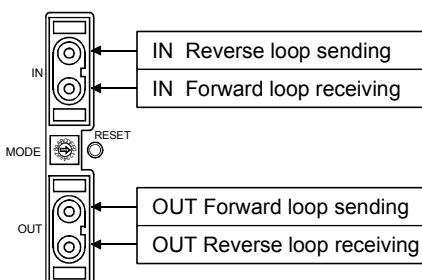

## 5. Wiring

### 5.1 Precautions for Laying Optical Fiber Cables

- (1) When optical fiber cable is connected, there are restrictions for the bending radius of the cable.

For details, check the specifications of the cable to be used.

- (2) Please maintain the optical fiber cable permissible bending radius with a checking tool.

Enquiries for the checking tool for optical fiber cable bending radius maintenance are handled by Mitsubishi Electric Europe GmbH. Please contact Mitsubishi Electric Europe GmbH for detail.

- (3) When laying the optical fiber cable, do not touch the fiber core of the cable connector or module connector, or let dirt or dust collect on it.

If oil from the hands, dirt or dust should adhere to the core, the transmission loss will increase, causing a malfunction in the data link.

Also, do not remove the cover from the module connector until an optical fiber cable is connected.

- (4) When attaching or detaching the optical fiber cable to/from the module, hold the cable connector securely with the hands.

- (5) Connect the cable connector and module connector securely until you hear a "click" sound.

- (6) Completely turn off the externally supplied power used in the system when connecting or disconnecting the cable.

- (7) Connect the optical fiber cables as shown below.

(a) QJ71LP21GE-QJ71LP21GE

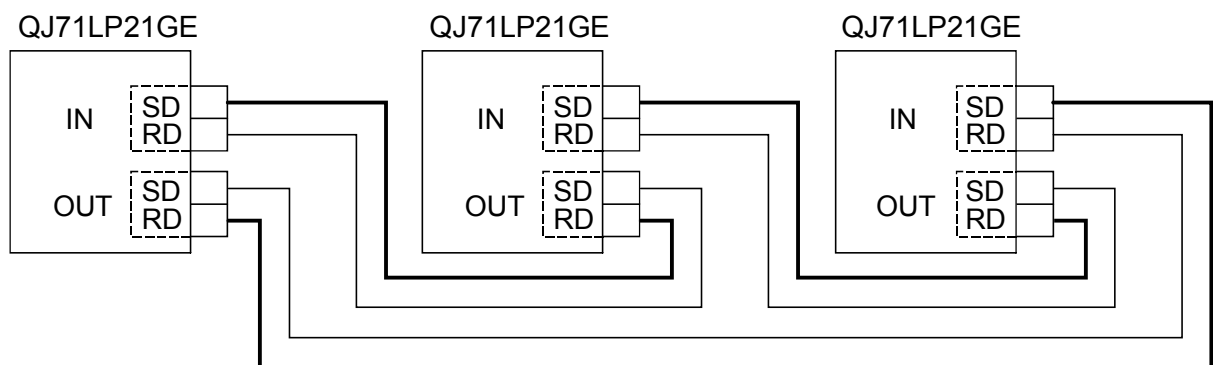

(b) QJ71LP21GE-QJ72LP25GE

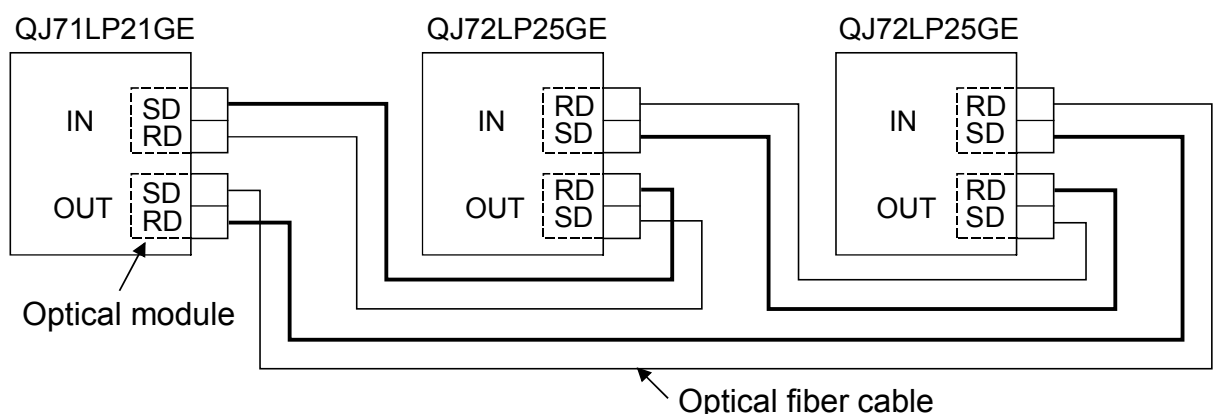

## 6. External Dimensions

### (1) QJ71LP21GE

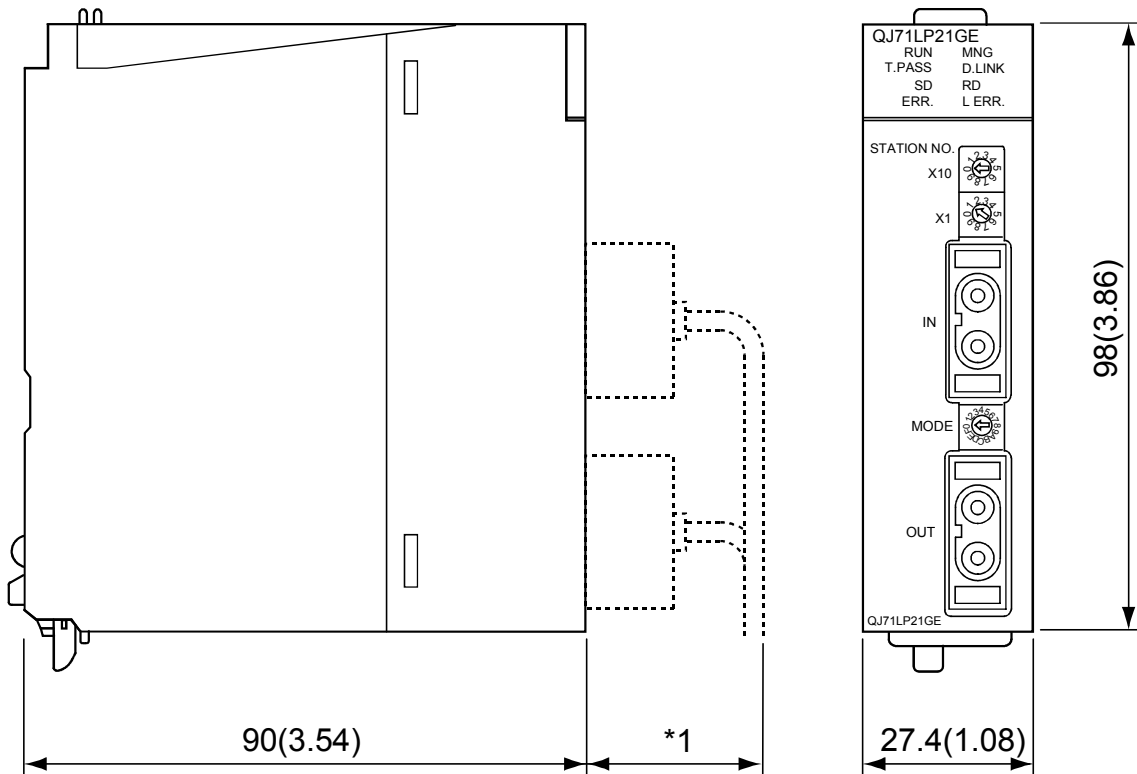

\*1: Please contact Mitsubishi Electric Europe GmbH for detail.

Unit: mm (in.)

### (2) QJ72LP25GE

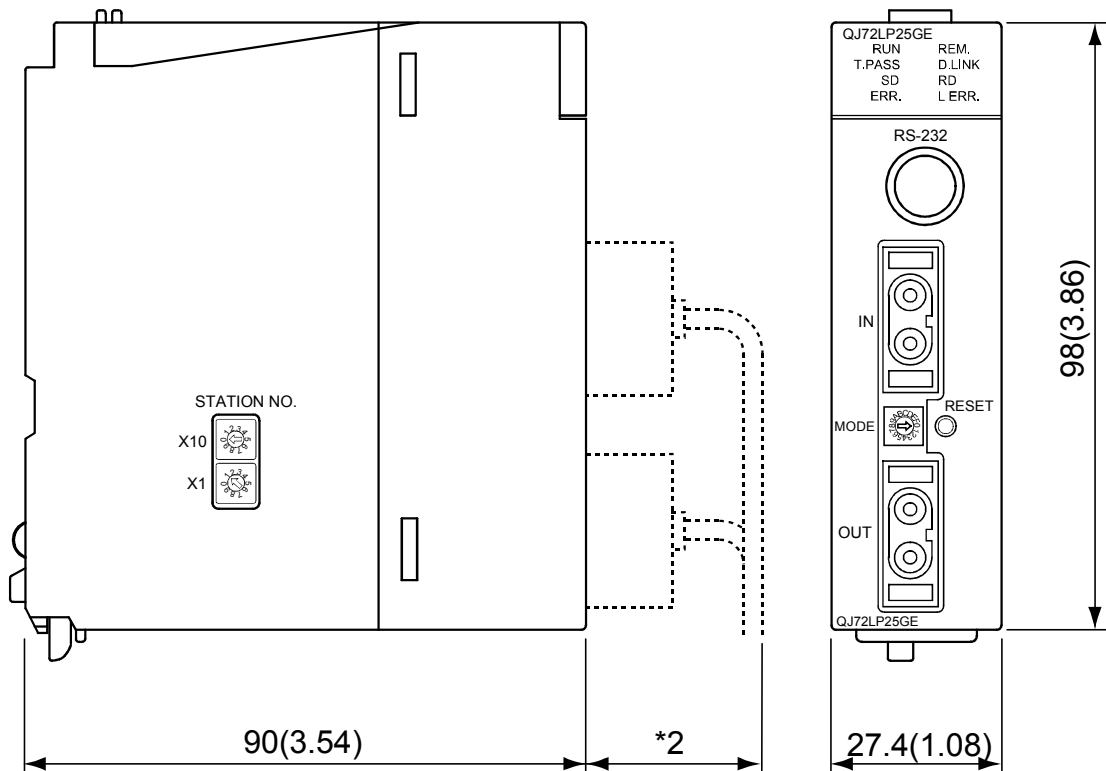

\*2: Please contact your nearest Mitsubishi Electric System Service Corporation for detail.

Unit: mm (in.)

## Warranty

Mitsubishi will not be held liable for damage caused by factors found not to be the cause of Mitsubishi; machine damage or lost profits caused by faults in the Mitsubishi products; damage, secondary damage, accident compensation caused by special factors unpredictable by Mitsubishi; damages to products other than Mitsubishi products; and to other duties.

### ⚠ For safe use

- This product has been manufactured as a general-purpose part for general industries, and has not been designed or manufactured to be incorporated in a device or system used in purposes related to human life.
- Before using the product for special purposes such as nuclear power, electric power, aerospace, medicine or passenger movement vehicles, consult with Mitsubishi.
- This product has been manufactured under strict quality control. However, when installing the product where major accidents or losses could occur if the product fails, install appropriate backup or failsafe functions in the system.

Country/Region	Sales office/Tel	Country/Region	Sales office/Tel
U.S.A	Mitsubishi Electric Automation Inc. 500 Corporate Woods Parkway Vernon Hills, IL 60061, U.S.A. Tel : +1-847-478-2100	Hong Kong	Mitsubishi Electric Automation (Hong Kong) Ltd. 10th Floor, Manulife Tower, 169 Electric Road, North Point, Hong Kong Tel : +852-2887-8870
Brazil	MELCO-TEC Rep. Com.e Assessoria Tecnica Ltda. Rua Correia Dias, 184, Edificio Paraiso Trade Center-8 andar Paraiso, Sao Paulo, SP Brazil Tel : +55-11-5908-8331	China	Mitsubishi Electric Automation (Shanghai) Ltd. 4/F Zhi Fu Plazz, No.80 Xin Chang Road, Shanghai 200003, China Tel : +86-21-6120-0808
Germany	Mitsubishi Electric Europe B.V. German Branch Gothaer Strasse 8 D-40880 Ratingen, GERMANY Tel : +49-2102-486-0	Taiwan	Setsuyo Enterprise Co., Ltd. 6F No.105 Wu-Kung 3rd.Rd, Wu-Ku Hsiang, Taipei Hsine, Taiwan Tel : +886-2-2299-2499
U.K	Mitsubishi Electric Europe B.V. UK Branch Travellers Lane, Hatfield, Hertfordshire., AL10 8XB, U.K. Tel : +44-1707-276100	Korea	Mitsubishi Electric Automation Korea Co., Ltd. 1480-6, Gayang-dong, Gangseo-ku Seoul 157-200, Korea Tel : +82-2-3660-9552
Italy	Mitsubishi Electric Europe B.V. Italian Branch Centro Dir. Colleoni, Pal. Perseo-Ingr.2 Via Paracelso 12, I-20041 Agrate Brianza., Milano, Italy Tel : +39-039-60531	Singapore	Mitsubishi Electric Asia Pte, Ltd. 307 Alexandra Road #05-01/02, Mitsubishi Electric Building, Singapore 159943 Tel : +65-6470-2460
Spain	Mitsubishi Electric Europe B.V. Spanish Branch Carretera de Rubi 76-80, E-08190 Sant Cugat del Valles, Barcelona, Spain Tel : +34-93-565-3131	Thailand	Mitsubishi Electric Automation (Thailand) Co., Ltd. Bang-Chan Industrial Estate No.111 Moo 4, Serithai Rd, T.Kannayao, A.Kannayao, Bangkok 10230 Thailand Tel : +66-2-517-1326
France	Mitsubishi Electric Europe B.V. French Branch 25, Boulevard des Bouvets, F-92741 Nanterre Cedex, France TEL: +33-1-5568-5568	Indonesia	P.T. Autoteknindo Sumber Makmur Muara Karang Selatan, Block A/Utara No.1 Kav. No.11 Kawasan Industri Pergudangan Jakarta - Utara 14440, P.O.Box 5045 Jakarta, 11050 Indonesia Tel : +62-21-6630833
South Africa	Circuit Breaker Industries Ltd. Private Bag 2016, ZA-1600 Isando, South Africa Tel : +27-11-928-2000	India	Messung Systems Pvt, Ltd. Electronic Sadan NO:III Unit No15, M.I.D.C Bhosari, Pune-411026, India Tel : +91-20-2712-3130
		Australia	Mitsubishi Electric Australia Pty. Ltd. 348 Victoria Road, Rydalmere, N.S.W 2116, Australia Tel : +61-2-9684-7777

## MITSUBISHI ELECTRIC CORPORATION

HEAD OFFICE : TOKYO BUILDING, 2-7-3 MARUNOUCHI, CHIYODA-KU, TOKYO 100-8310, JAPAN  
NAGOYA WORKS : 1-14, YADA-MINAMI 5-CHOME, HIGASHI-KU, NAGOYA, JAPAN

When exported from Japan, this manual does not require application to the Ministry of Economy, Trade and Industry for service transaction permission.

Specifications subject to change without notice.  
Printed in Japan on recycled paper.